

MONORAIL

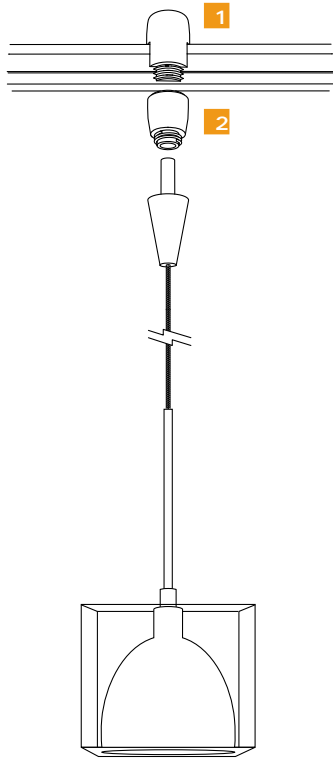

- 1** Monorail Adapter place "U" grooved part with male threads over monorail.
- 2** Raise bottom of monorail adapter with female threads mating with "U" part male threads.
- 3** Rotate clockwise till tight.
- 4** Be careful not to cross-thread when tightening.

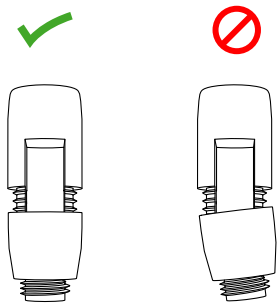

CABLE

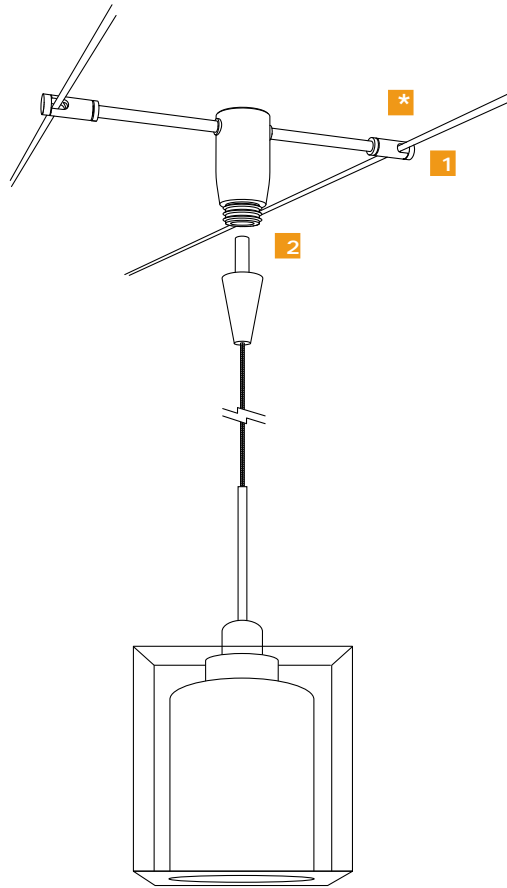

- 1** Strip insulated Cable aprox. 1/4" with sharp knife, make sure to not cut cable metal stranding, install EZ Jack Cable Adapter by loosening thumb screws, removing them. Place adapter ends over the stripped cable area, tighten thumbscrews into their threaded holes.
- 2** Raise pendant to mate with male threads, rotate clockwise till tight. Be careful not to cross-thread when tightening.

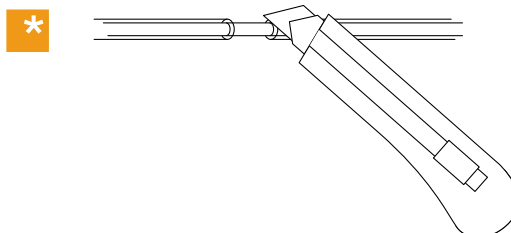

MONOPOINT

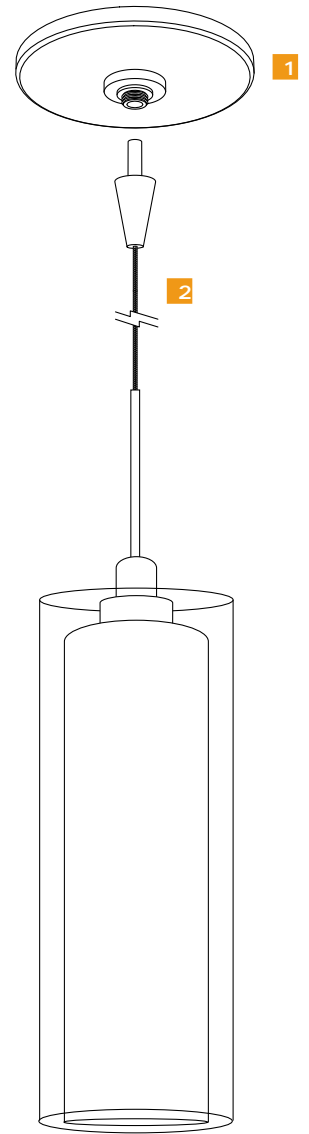

- 1** Mount monopoint canopy per enclosed instructions.
- 2** Raise pendant to mate with male threads, rotate clockwise till tight. Be careful not to cross-thread when tightening.

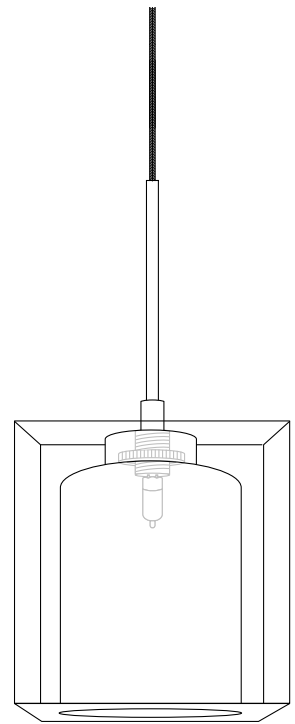
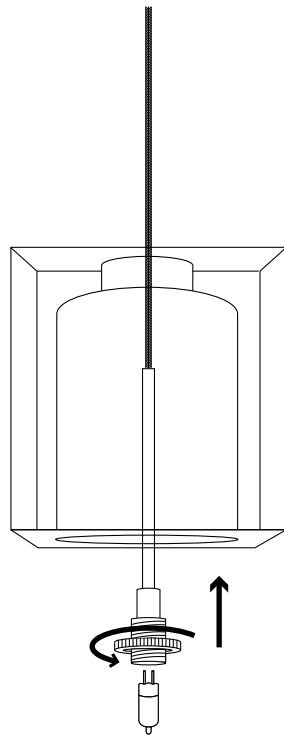
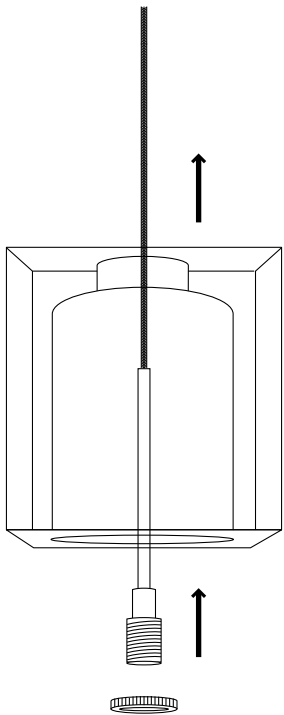

1 Feed coaxial cable as shown through applicable glass.

2 Rotate to raise or lower glass leveling nut. Raise or lower and fine adjust nut level so top of socket holder (threaded part) is level with top of glass.

3 Push the lamp pins all the way into the socket holes.

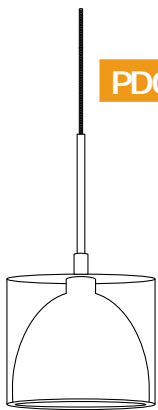

PDO65

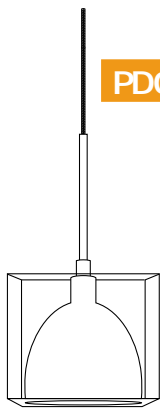

PDO63

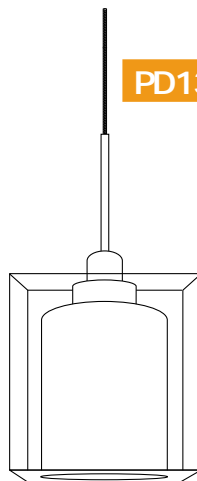

PD134

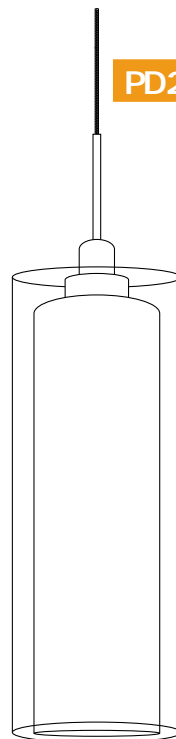

PD221

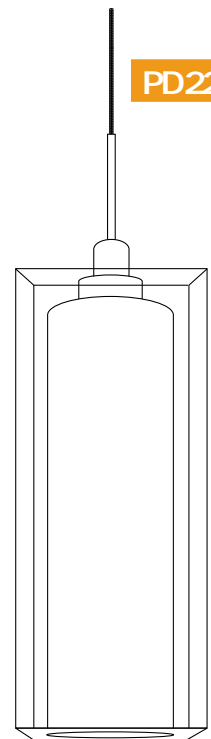

PD222

ADJUST THE FIXTURE HEIGHT

- 1 Cut the coaxial cable to the desired length with a sharp cutter. The overall fixture height (H) is measured from bottom of the glass shade to end of the coaxial cable.

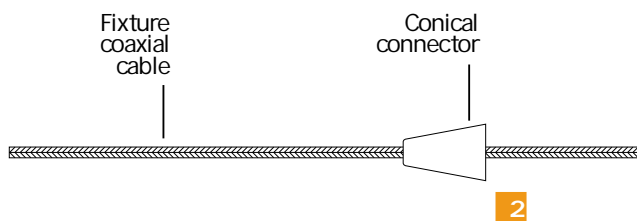
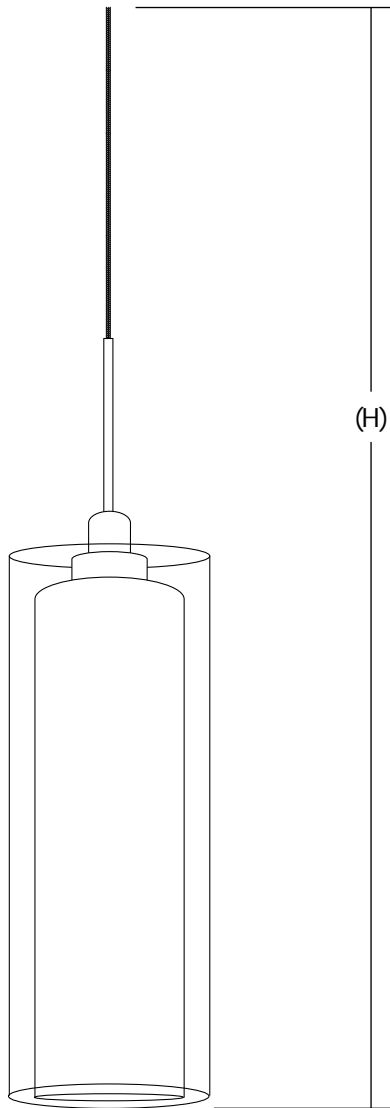

- 2 Insert the fixture coaxial cable through the conical connector



- 3 Insert the coaxial cable through the flared end of the strain relief.

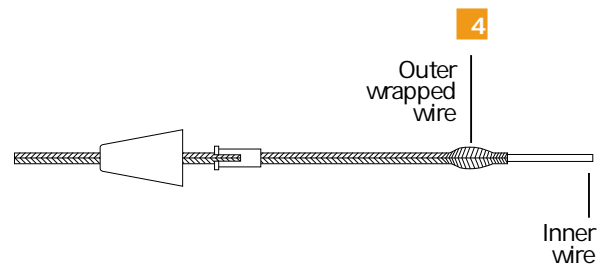

- 4 Slide the outer wrapped wire back to expose the inner wire.

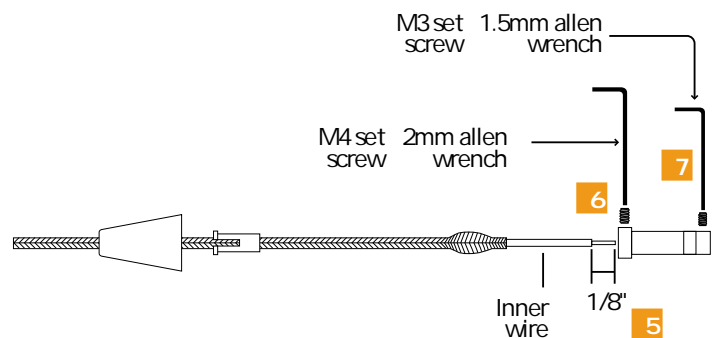

- 5 Strip 1/8" from end of the inner wire. Make sure that the stripped portion is not greater than 3/16".
- 6 Loosen (Do Not Remove) the M4 set screw with the provided 2mm Allen wrench.
- 7 Remove the M3 set screw with the provided 1.5mm Allen wrench.

